

---

DESPIECE TECNICO

---

**LAVADORAS**

**SERIES "EVOLUTION TECHNOLOGY"**

**Modelos:**

**LA-40 MP**



**PLATON SERVICE**

8 (800) 500-34-47

[www.platonservice.com](http://www.platonservice.com)

junio-09



**Fagor Industrial**

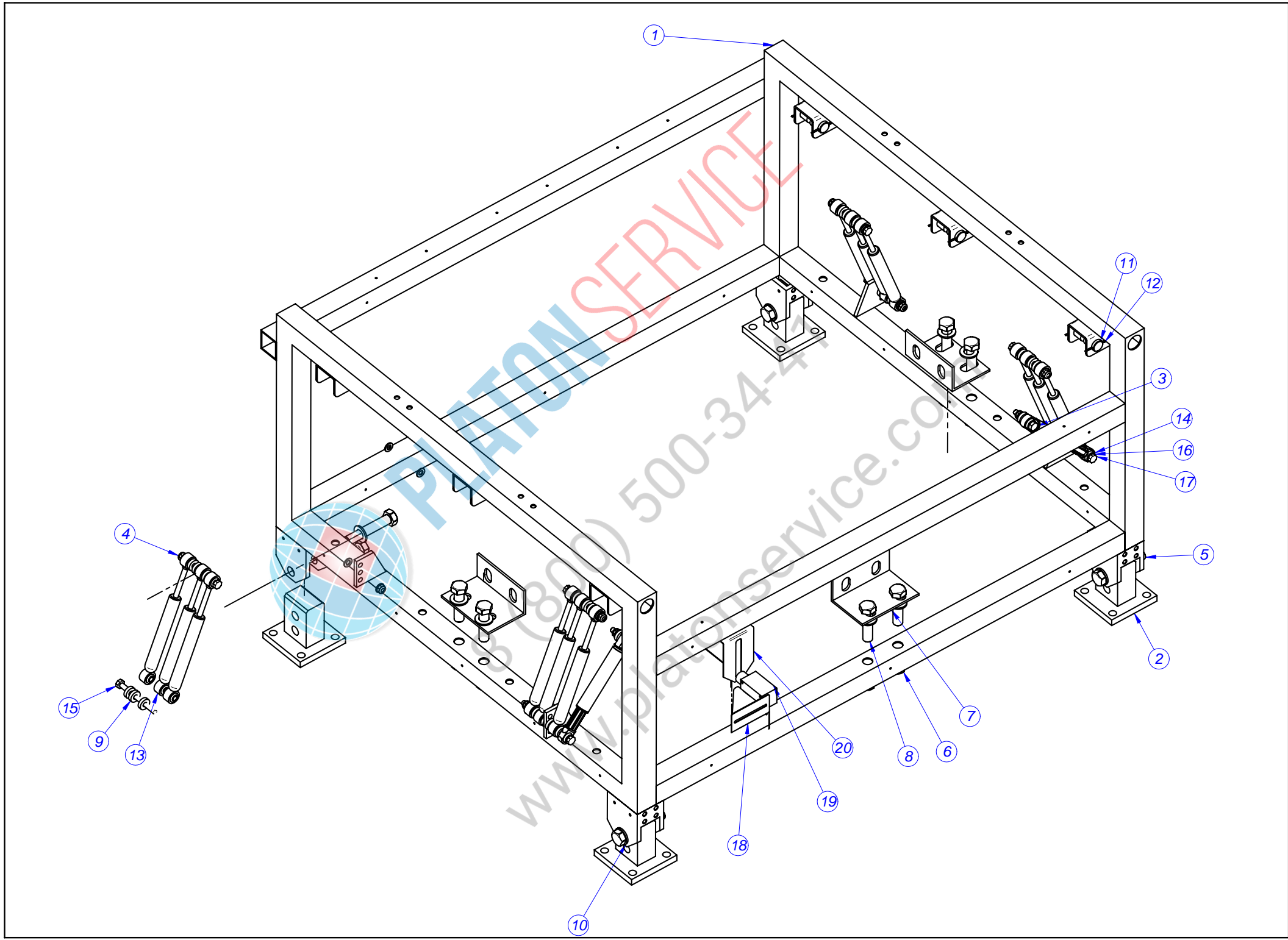

MOD.	LAVADORA LA-40		ZONA	ARMAZON	
Nº	CODIGO	DENOMINACION	Cant.		
1	P650101000	ARMAZON 40 COMPLETO	1		
2	P660107000	PATA RIGIDA 60	4		
3	Q151326000	TOR.EX.M10X55 H.ZINCADO	2		
4	Q221306000	TUE.EX.AUT.M10 8.8 ZIN	10		
5	Q151302000	TORNILLO EXAG.M.20x110	4		
6	Q221348000	TUERCA EXAG.AUTOBL.M.20	10		
7	P650103000	ANCLAJE LATERAL 40	3		
8	Q151354000	TORNILLO EXAG.M.20x80	6		
9	P620107000	CASQUILLO AMORTIGUADORES	28		
10	Q231311000	ARANDELA A21	20		
11	P540203000	PASADOR MUELLE 55Kg.	6		
12	Q352017000	PASADOR DE ALETAS 3 X 50	12		
13	P680220000	AMORTIGUADOR LF-120	16		
15	Q151356000	TORN.EXAG.M10X110	6		
16	Q232060000	ARANDELA A10	19		
17	Q151525000	EXAG. M10X150(8.8) DIN931	2		
18	P663012000	SOPORTE MICRO DESEQ. V2	1		
19	P543051000	FINAL DE CARRERA VARILLA	1		
20	P663013000	RANURA MICRO DESEQUILIBRIO	1		
21	P663010000	CABLE MICRO DESEQUILIBRIO	1		

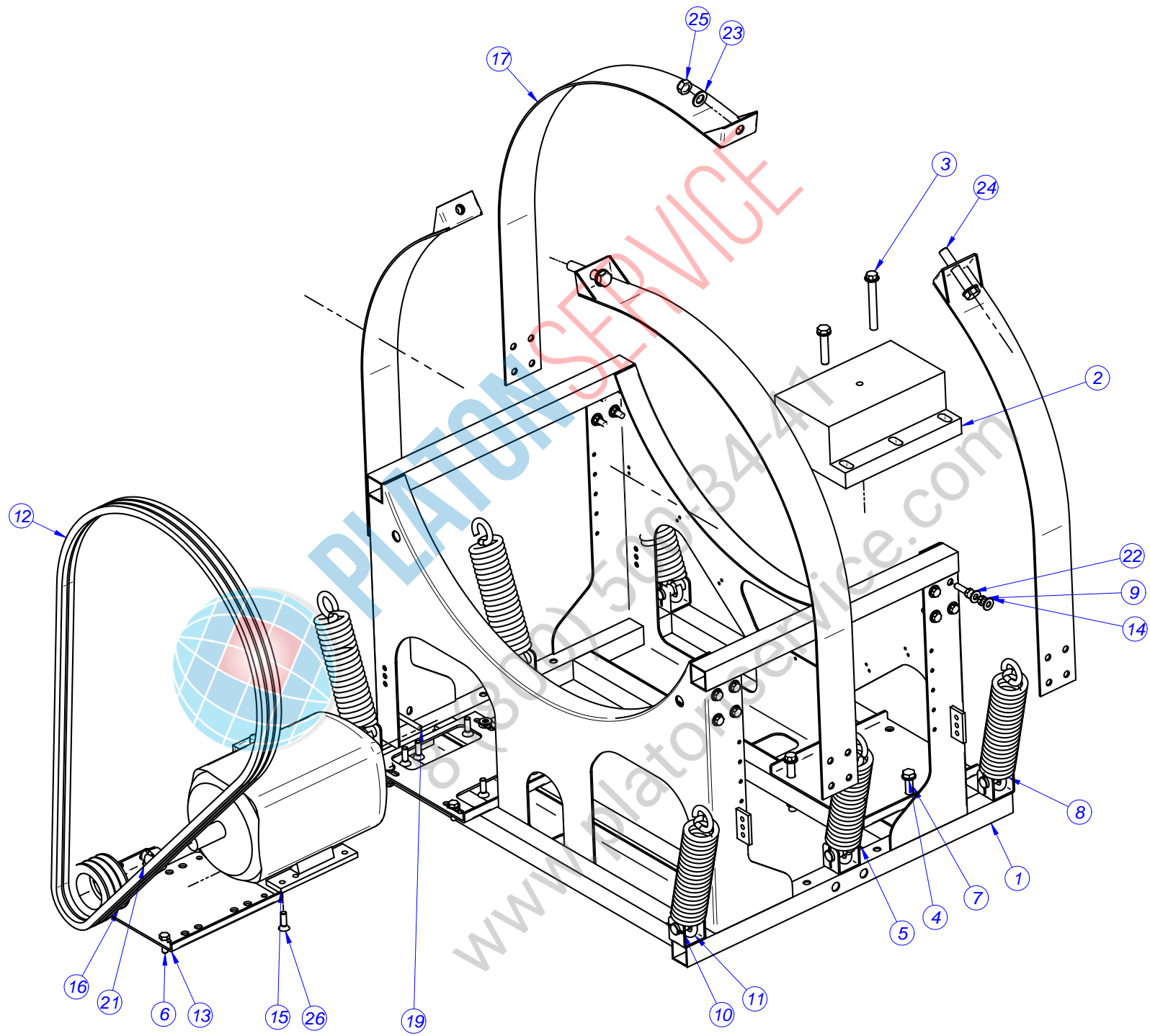

MOD.		LAVADORA LA-40	ZONA	CUNA
Nº	CODIGO	DENOMINACION	Cant.	
1	P650206000	CUNA COMPLETA 40	1	
2	P650210000	CONTRAPESO MOTOR 40	1	
3	Q151592000	TORN.EXA. M16x130	4	
4	Q232061000	ARANDELA A16 DIN 125	12	
5	Q221347000	TUERCA EXAG.AUTOBL.M.16	6	
6	Q151341000	TOR.EX.M12X35 H.ZINCADO	3	
7	Q151399000	TORN. EXAG.M.16x80 DIN 933	2	
8	P540203000	PASADOR MUELLE 55Kg.	6	
9	Q221307000	TUE.EX.AUT.M12 H.ZINCADA	22	
10	Q352017000	PASADOR DE ALETAS 3 X 50	12	
11	P650211000	MUELLE LF-40	6	
12	P655902000	CORREA SPB 40	3	
13	P660205000	PLACA SOPORTE MOTOR 60	1	
14	Q301010000	ARAND 27X12,5X2,5HIER	40	
15	P655903000	MOTOR 7.5 KW	1	
16	P545922000	POLEA MOTOR SPB/B 118-3	1	
17	P650205000	CINTA SOPORTE CUBA 40	4	
19	Q011360000	TORNILLO EXAGONAL M10X80	1	
21	P545917000	TAPER BUSH MOTOR	1	
22	Q011376000	TOR.EX.M12X40 H.ZINCADO	16	
23	Q231311000	ARANDELA A21	4	
24	Q151302000	TORNILLO EXAG.M.20x110	2	
25	Q221348000	TUERCA EXAG.AUTOBL.M.20	2	
26	Q151595000	TOR. AVELLANADO M12x40	6	

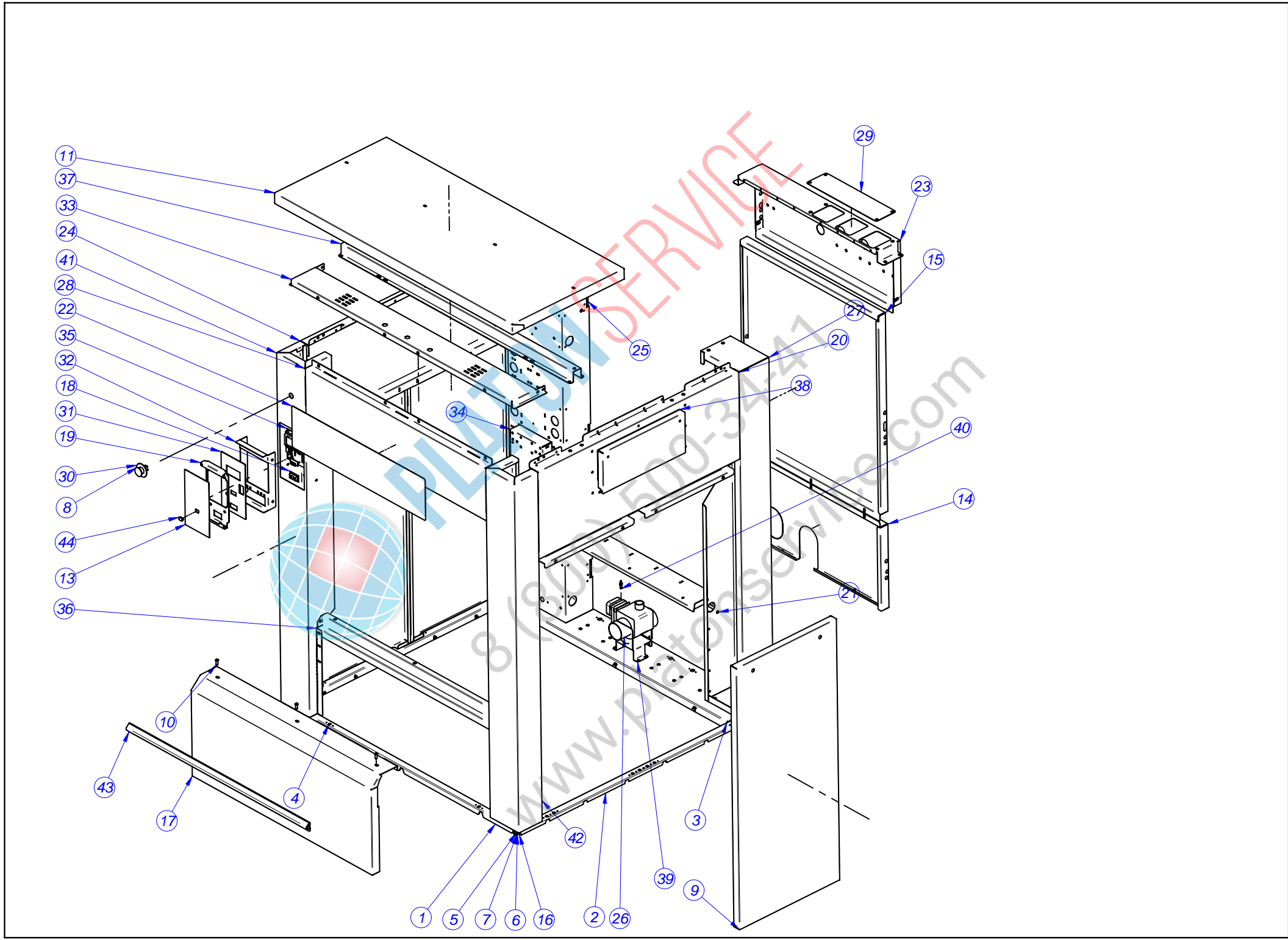

MOD.	LAVADORA 40		ZONA	MUEBLE	
Nº	CODIGO	DENOMINACION	Cant.		
1	P660319000	LISTON ARMAZON ANT.60	1		
2	P650316000	LISTON ARMAZON LAT.40	2		
3	P660317000	LISTON ARMAZON POST.60	1		
4	Q151323000	TORN.BROCA 4,8X16	16		
5	Q221344000	REMACHE EXAGONAL M8	18		
6	Q232050000	ARANDELA A8	6		
7	Q242050000	ARAND.ABAN. A8 A.304	6		
8	Z513005000	Interruptor de seta rojo	1		
9	P650303000	PANEL LATERAL INFERIOR 40	2		
10	Q152065000	TOR. M8X20 ISO 7380 A2	3		
11	P650311000	ENCIMERA ANTERIOR 40	1		
13	P540375000	ADHESIVO PORTAMANDOS 55 MPP	1		
14	P660304000	PANEL VACIADO 60	1		
15	P660305000	PANEL POST. INTERMEDIO 60	1		
16	Q012053000	TORN.EXA. M8X20 A.304	6		
17	P660352000	ZOCALO V2 60	1		
18	P623017000	INTERRUPTOR GENERAL C.I.	1		
19	P660344000	PORTA PROGRAMADOR COLUMNA 60	1		
20	P650328000	PANEL LAT CUBETERA COMPL.40	1		
21	P660320000	SOPORTE PANELES POST. 60	1		
22	P540376000	ADHESIVO PORTAMANDOS 55	1		
23	P660306000	PANEL POST. VALVULAS 60	1		
24	P650302000	PANEL LATERAL SUPERIOR 40	1		
25	P660310000	CUADRO ELECTRICO 60	1		
26	P532103000	VALVULA VACIADO	1		
27	P660309000	COLUMNA POSTERIOR 60	1		
28	P660301000	PORTAMANDOS 60	1		
29	P660354000	TAPA VALVULAS 60	1		
30	Z513006000	Etiqueta circular amarillo	1		
31	P660345000	PORTA ADHESIVO COLUMNA 60	1		
32	P660346000	SOPORTE PROGR. INTERIOR 60	1		
33	P660342000	TRAVESANO PORTAMANDOS 60	1		
34	P660333000	CAJA VARIADOR 60	1		
35	P643008000	VISUALIZADOR GRAFICO MP	1		
36	P660324000	SOPORTE ZOCALO 60	1		
37	P660321000	SOPORTE ENCIMERA 60	1		
38	P540404000	PUERTA CUBETERA COMPLETA	1		
39	P652101000	APOYO VALVULA	1		
40	X012612000	PITON CIERRE	1		
41	P660347000	COLUMNA ANTERIOR IZDA. V2 60	1		
42	P660348000	COLUMNA ANTERIOR DER. V2 60	1		
43	P540370000	PARACHOQUES 55KG	1		
44	P6130140000	TAPON PUERTO SERIE PROG	1		

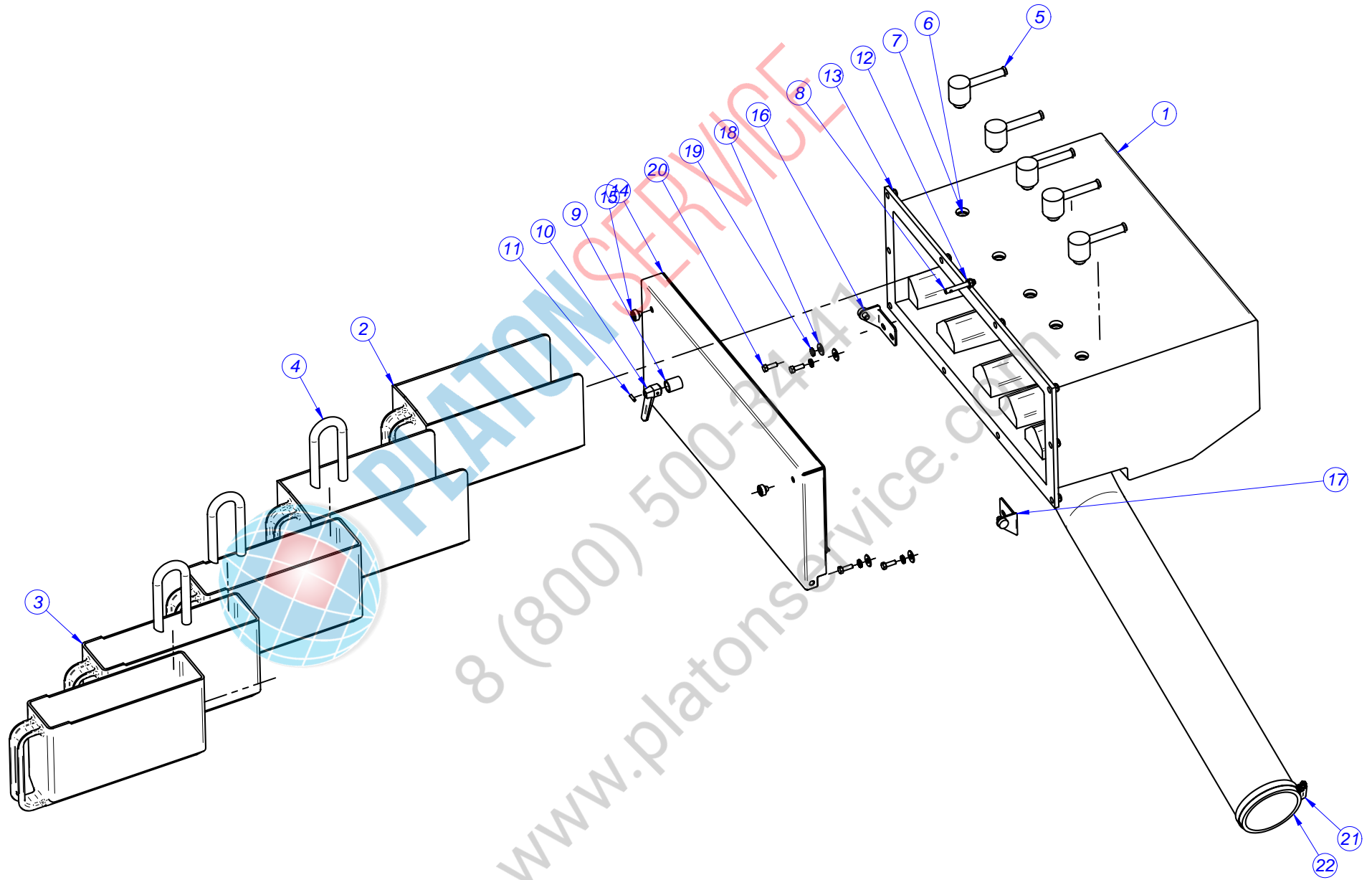



MOD.	LAVADORA 40-60		ZONA	CUBETERA	
Nº	CODIGO	DENOMINACION	Cant.		
1	P540702000	CUBETERA LF-55	1		
2	P540704000	CUBETA DETERGENTES LF-55	2		
3	P540705000	CUBETA LIQUIDOS LF-55	3		
4	P440702000	TUBO SIFON	3		
5	P530708000	PASAMUROS COMPLETO	5		
6	Q307002000	JUNTA DE GOMA 3031986	5		
7	Q223018000	TUERCA 16X1,5	5		
8	P540353000	EJE CIERRE CUBETERA	1		
9	P540354000	CASQUILLO SEPARADOR CIERRE	1		
10	P530714000	MANGO CUBETERA	1		
11	Q372002000	MANGUITO SUJ.3X12 DIN1481	1		
12	Q232030000	ARANDELA A5	11		
13	Q222012000	TUER.AUTOB.M6	11		
14	P540404000	PUERTA CUBETERA COMPLETA	1		
15	R670617000	TOPE CRISTAL INTERIOR	2		
16	P540357000	BISAGRA CUBETERA IZDA. COMPL	1		
17	P540356000	BISAGRA CUBETERA DCHA. COMPL	1		
18	Q302022000	ARANDELA 16X6X1.2 A.304	4		
19	Q242030000	ARAND.ABAN. A5 A.304	4		
20	Q012032000	TORN.EXA. M5X15 A.304	4		
21	Q881326000	ABRAZADERA 70-90	2		
22	P532119000	CONDUCTO LLENADO LC-LF 25	1		

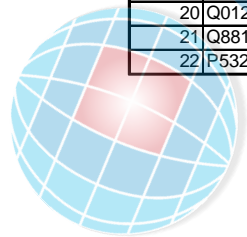

8 (800) 500-3447

www.platonservice.com

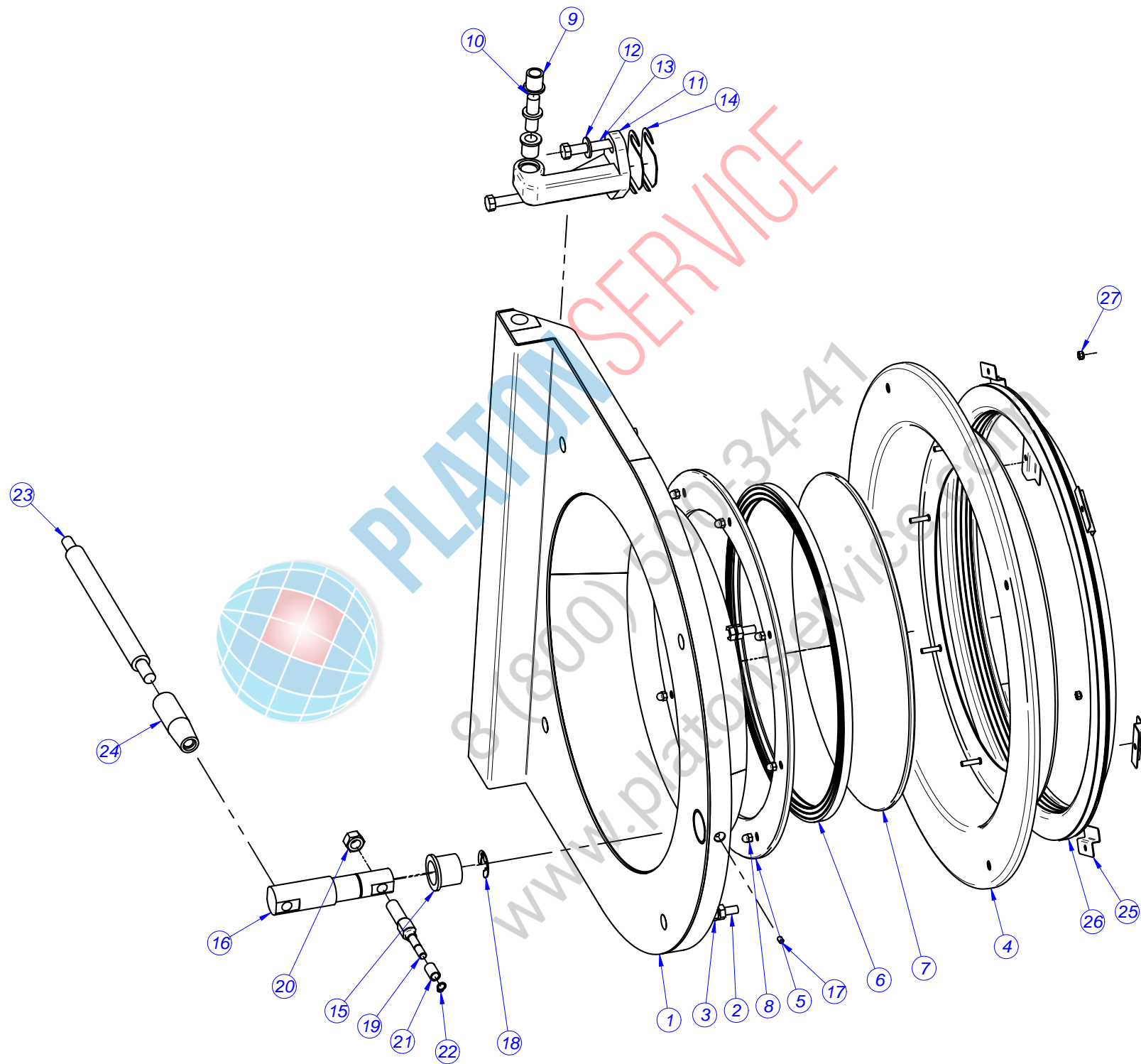

MOD.	LAVADORA 40-60		ZONA	PUERTA	
Nº	CODIGO	DENOMINACION	Cant.		
1	P660530000	PUERTA COMPL.60/40 V3	1		
2	P680515000	VARILLA ROSCADA PUERTA 120	4		
3	Q162066000	TUERCA EXAGONAL M10 INOX.	12		
4	P660502000	PUERTA PISADOR COMPL.60	1		
5	P540502000	EMBELL.MARCO PUERTA	1		
6	P540505000	JUNTA MIRILLA 55	1		
7	P540503000	MIRILLA PUERTA 55	1		
8	Q212040000	TUER.SOMB.M6	8		
9	P680511000	CASQUILLO "SELFOIL 16-22-25	4		
10	P680548000	EJE BISAGRA	2		
11	P660527000	BISAGRA PUERTA 60	2		
12	Q301010000	ARAND 27X12.5X2.5HIER	4		
13	Q011376000	TOR.EX.M12X40 H.ZINCADO	4		
14	P660529000	CALZO BISAGRA 60,40	4		
15	P680526000	CASQUILLO SELFOIL DE VALONA	1		
16	P660528000	EJE PUERTA 40/60	1		
17	Q132041100	VARILL. ROSC. EXTR. CON. M6X	1		
18	Q272072000	ARAND. SEG. A24 DIN6799 INOX	1		
19	P660521000	EJE LEVA PUERTA 60/40	1		
20	Q162090000	TUER.EXA.M16	1		
21	P540516000	CASQUILLO ENGANCHE	1		
22	Q302060000	ANILLO SEG. A10 DIN471	1		
23	P680528000	PALANCA LEVA 120	1		
24	P680531000	MANGO PUERTA 120	1		
25	P680530000	SOPORTE GOMA 120	6		
26	P660535000	JUNTA PUERTA 60	1		
27	Q222012000	TUER.AUTOB.M6	6		
28	P540519000	SEPARADOR CRISTAL	8		
29	P540520000	PISADOR CRISTAL	8		

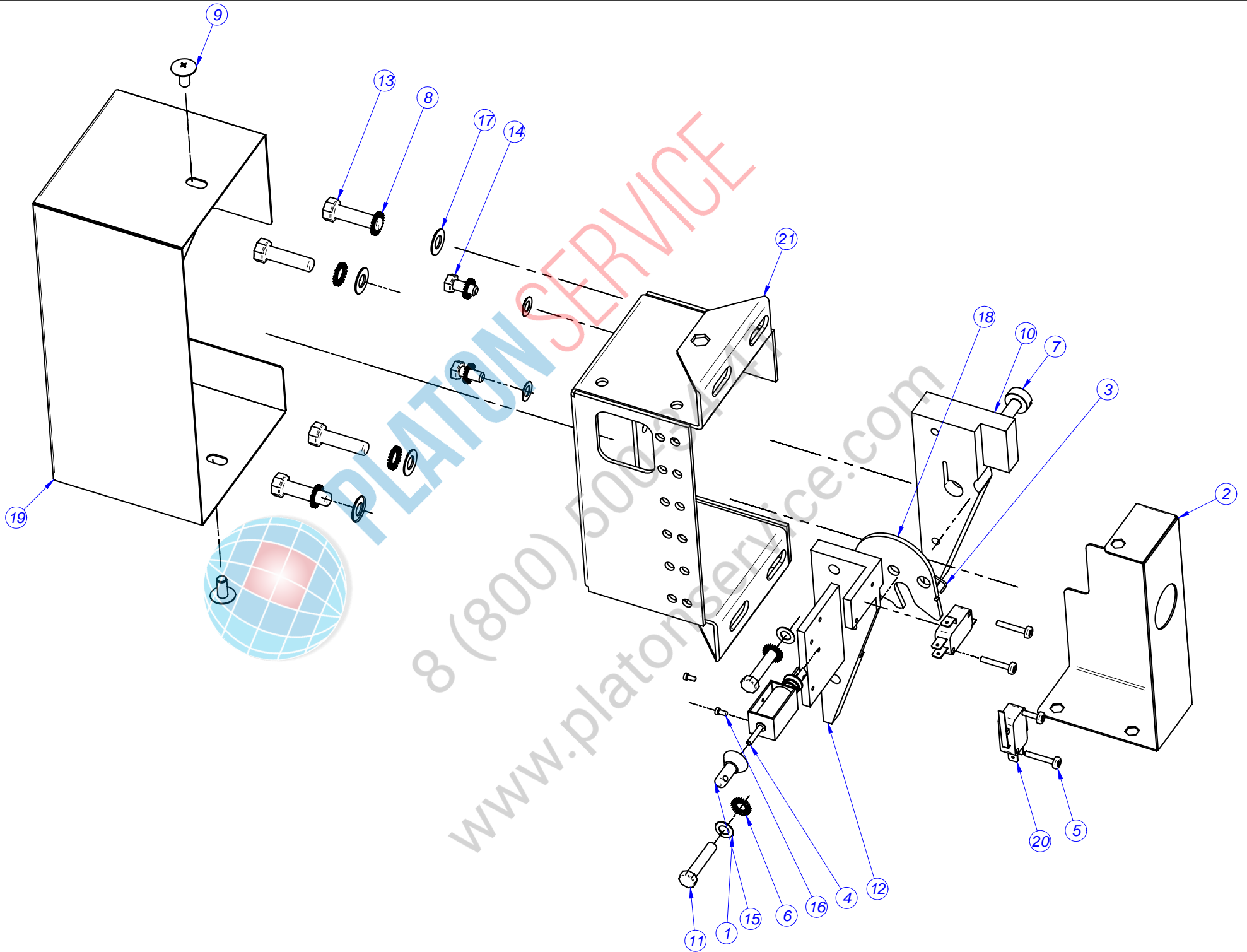

PLATON SERVICE  
8 (800) 500-5000  
www.platon-service.com

MOD.	LAVADORA 40-60		ZONA	CIERRE P650507000	
Nº	CODIGO	DENOMINACION	Cant.		
1	Q232030000	ARANDELA A5	4		
2	P650508000	PROTECTOR CONEXIONES CIERRE	1		
3	P620510000	MUELLE CIERRE	1		
4	P613002000	ELECTROIMAN PUERTA	1		
5	Q032013000	TORN.ALOM.M3X20	4		
6	Q242040000	ARAND.ABAN. A6 A.304	4		
7	P650506000	EJE BLOQUEO 40,60,120	1		
8	Q242050000	ARAND.ABAN. A8 A.304	4		
9	Q152017000	TORN.AMAR.M6X13 A304	2		
10	P650503000	LEBA CIERRE 40,60,120	1		
11	Q012045000	TORN.EXA. M6X30 A.304	2		
12	P650502000	BASE CIERRE 40,60,120	1		
13	Q012055000	TORN.EXA. M8X30 A.304	4		
14	Q012042000	TORN.EXA. M6X15	2		
15	P620529000	DESBLOQUEO	1		
16	Q151396000	TORN. ALLEN M2.5x5	2		
17	Q232050000	ARANDELA A8	4		
18	P650504000	BLOQUEO CIERRE 40,60,120	1		
19	P650505000	TAPA CIERRE 40,60	1		
20	P620526000	INTERRUPTOR PUERTA PLANO	2		
21	P650501000	SOPORTE CIERRE 40,60,120	1		
22	P623010000	Cableado Puerta	1		

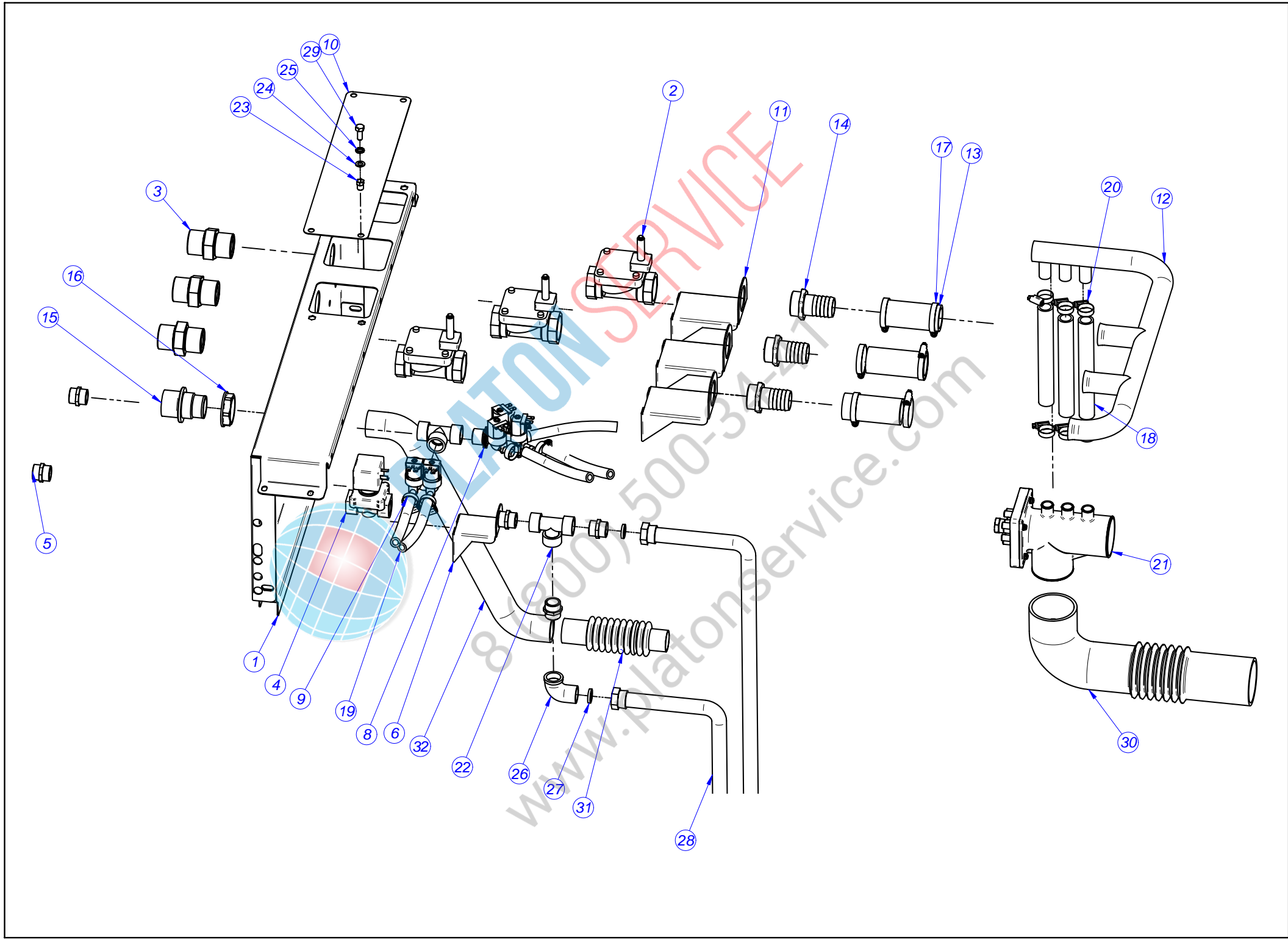

MOD.	LAVADORA 40-60		ZONA	MUEBLE	
Nº	CODIGO	DENOMINACION	Cant.		
1	P660306000	PANEL POST. VALVULAS 60	1		
2	P665001000	VALVULA 1 1/4"	3		
3	P666505000	GM 2020 UNION GAS 11/4" 11/4	3		
4	P505012000	VALVULA VAPOR 1/2" 50HZ	1		
5	Z102301000	MANGUITO 3/4"	5		
6	P665009000	SOPORTE VALVULA VAPOR 3/4	1		
8	Z611123000	E.V. TRIPLE COD.255.641	1		
9	P255001000	ELECTROVALVULA DOBLE	1		
10	P660354000	TAPA VALVULAS 60	1		
11	P665010000	SOPORTE VALVULA 1 1/4	3		
12	P665011000	TUBO ENTRADAS DE AGUA 1 1/4	1		
13	P502106000	TUBO REBOSADERO	3		
14	P665012000	RACOR-MANGUERA 1"1/4	3		
15	Z740701000	PASAMUROS ARBOL LAVADO	1		
16	Z710708000	TUERCA PASAMUROS	1		
17	Q881306000	ABRAZADERA 32-50L	6		
18	3714800000	TUBO GOMA NEGRA D 26*19	3		
19	3676900000	TUBO GOMA NEGRA D 17*10	5		
20	Q881336000	ABRAZADERA 16-27	11		
21	P640705000	TOMA DOSIFICACIÓN COMP. 25	1		
22	P535020000	Te a 90°-3/4"	1		
23	Q221344000	REMACHE EXAGONAL M8	1		
24	Q232050000	ARANDELA A8	1		
25	Q242050000	ARAND.ABAN. A8 A.304	1		
26	Z718421000	CODO M-H 3/4" LATON	1		
27	P535024000	ARANDELA TEFLON 24X15X4	2		
28	P665007000	LATIGUILLO VAPOR 60	2		
29	Q012053000	TORN.EXA. M8X20 A.304	1		
30	P630701000	CONDUCTO DOSIFICADOR CUBA 18	1		
31	P620708000	CONDUCTO SALIDA VAPOR	1		
32	P542109000	COND. REBOSADERO INF. LF-55	1		

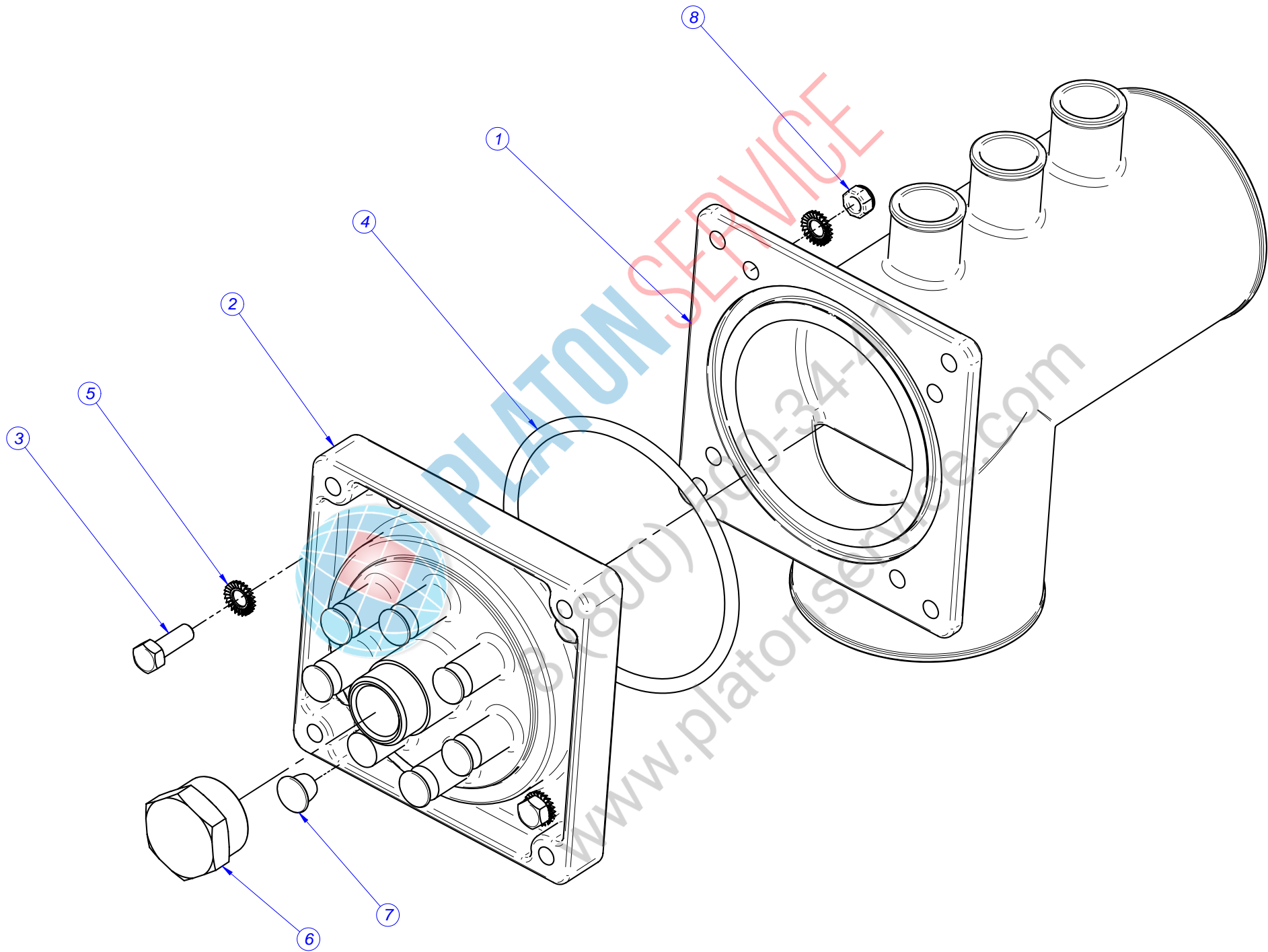



MOD.		LAVADORA 25	ZONA	DOSIFICACION	
Nº	CODIGO	DENOMINACION	Cant.		
	P640705000	TOMA DOSIFICACION COMPLETA	1		
1	P530730000	TOMA DOSIFICACION INT. P	1		
2	P620706000	TOMA DOSIFICACION EXTERIOR	1		
3	Q012032000	TORN.EXA. M5X15 A.304	4		
4	Q307081000	JUNTA TORICA 75x4	1		
5	Q242030000	ARAND.ABAN. A5 A.304	8		
6	P620710000	TAPA 1/2"	1		
7	P620709000	TAPON DOSIFICADORES	7		
8	Q222030000	TUER.AUTOB.M5	4		



8 (800) 500-34-47

www.platonservice.com

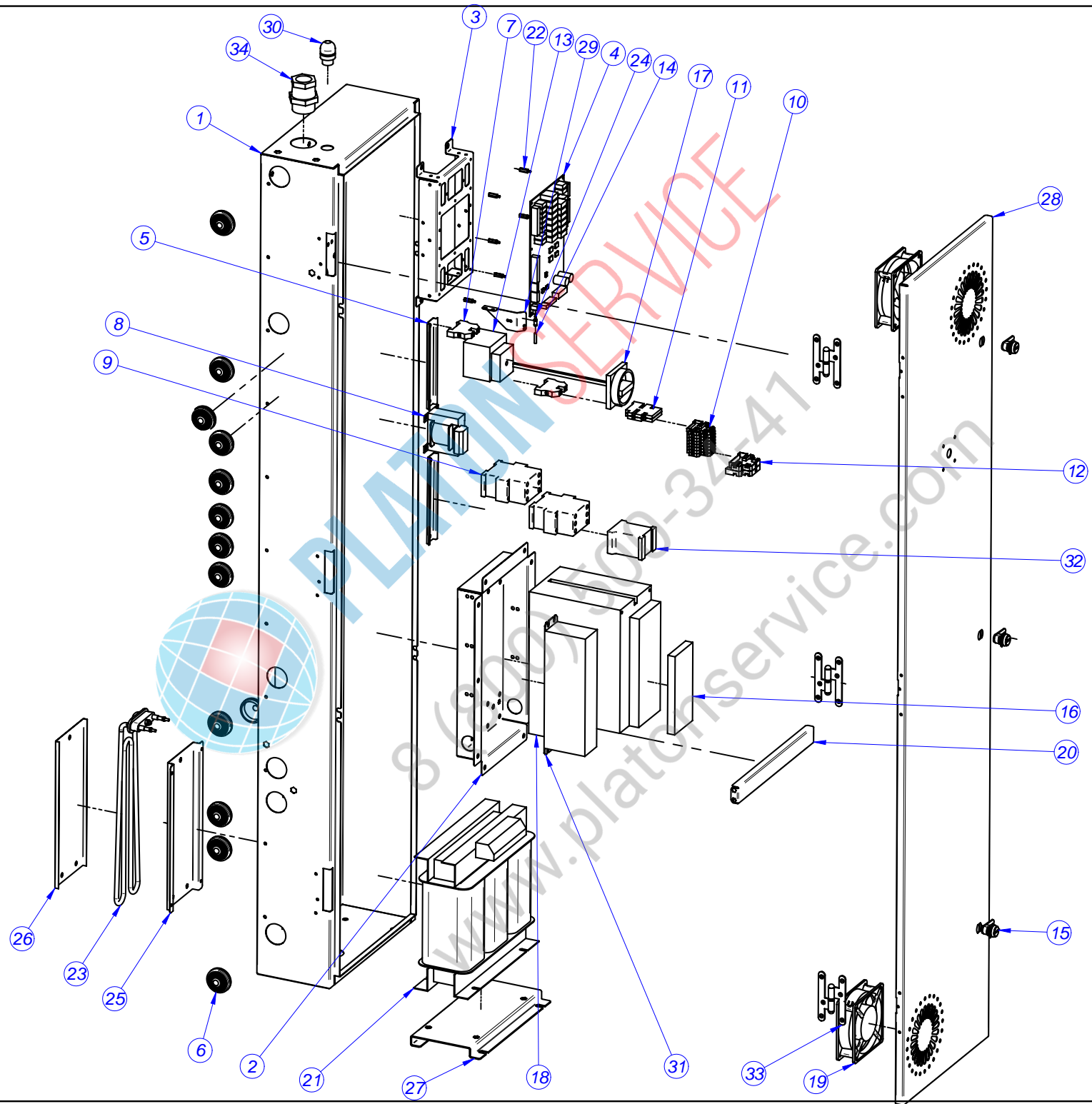

MOD.	LAVADORA 40-60		ZONA	MUEBLE	
Nº	CODIGO	DENOMINACION	Cant.		
1	P660310000	CUADRO ELECTRICO 60	1		
2	P660333000	CAJA VARIADOR 60	1		
3	P643009000	SOPORTE VISUALIZADOR MP	1		
4	P613005000	PLACA ENTRADAS-SALIDAS	1		
5	Z123019000	GUIA CONTACTOR L-175	2		
6	N103013000	PASA CABLES	13		
7	P453026000	BORNE TIER 10 WPE-10103.O	2		
8	P623028000	TRANSFORMADOR 0-20-0-230	1		
9	X183011000	CON.3RT1024-1AN20 230V 50H	2		
10	P623006000	REGLETA BORNAJE 2 PISOS	8		
11	R073005000	BORNAS PORTA FUSIBLES	2		
12	Z263303000	TOPE FINAL	2		
13	P683039000	SECCIONADOR 63A(VERSION 400V)	1		
13	P663016000	SECCIONADOR 125A (VERSION 230V)			
14	3721910000	TUBO CRISTAL 4	1		
15	P620351000	CERRADURA 0185	3		
16	P663009000	DISPLAY KEB 00.75.060-1000	1		
18	P663001000	VARIADOR 11 KW KEB (60)	1		
18	P653001000	VARIADOR 7.5 KW KEB (40)	1		
19	Z103066000	VENTILADOR 230V.50-60HZ	2		
20	P660312000	NERVIO CUADRO ELECTRICO 60	1		
21	P666522000	AUTOTR III 220/380V 11KVA (VERSION 230V)	1		
22	T133007000	DISTANCIADOR M3	6		
23	Z203601000	RESISTENCIA TANQUE	1		
24	P613021000	REDUCCION PRESOSTATO	1		
25	P683010000	BASE RESISTENCIA VARIADOR	1		
26	P683011000	TAPA RESIST. VARIADOR	1		
27	P666529000	SOPORTE TRAF0 220/380V 11KW (VERSION 230V)	1		
28	P660314000	PUERTA CUADRO ELECTRICO 60	1		
29	P620359000	SUJECION MANGUERA PRESOSTATO	1		
30	R033002000	PRENSA ESTOPAS	1		
31	P663005000	FILTRO 60/40(15.E4.T60-3A01)	1		
32	Z203050000	CONTAC. SIRUS 3R 230V 50-60	1		
33	P680328000	BISAGRA AUTOSERVICIO	3		
34	R143010000	PRENSA ESTOPA PG-36	1		
35	P643018000	Cable de ventilador	1		
36	P663004000	INSTALACION ELECT.: 60kg, 40kg	1		
37	P663006000	Cableado de motor: 60Kg, 40kg	1		
38	P663007000	Cable resistencias:60kg, 40kg	1		
39	P184011000	CARTUCHO FUSIBLE 4.A	2		
40	P643005000	Ptc+Puente rectificador Electr	1		
41	P643018000	Cable de ventilador	2		
42	P683027000	CABLEADO PROG. - TECLADO 120Kg	1		

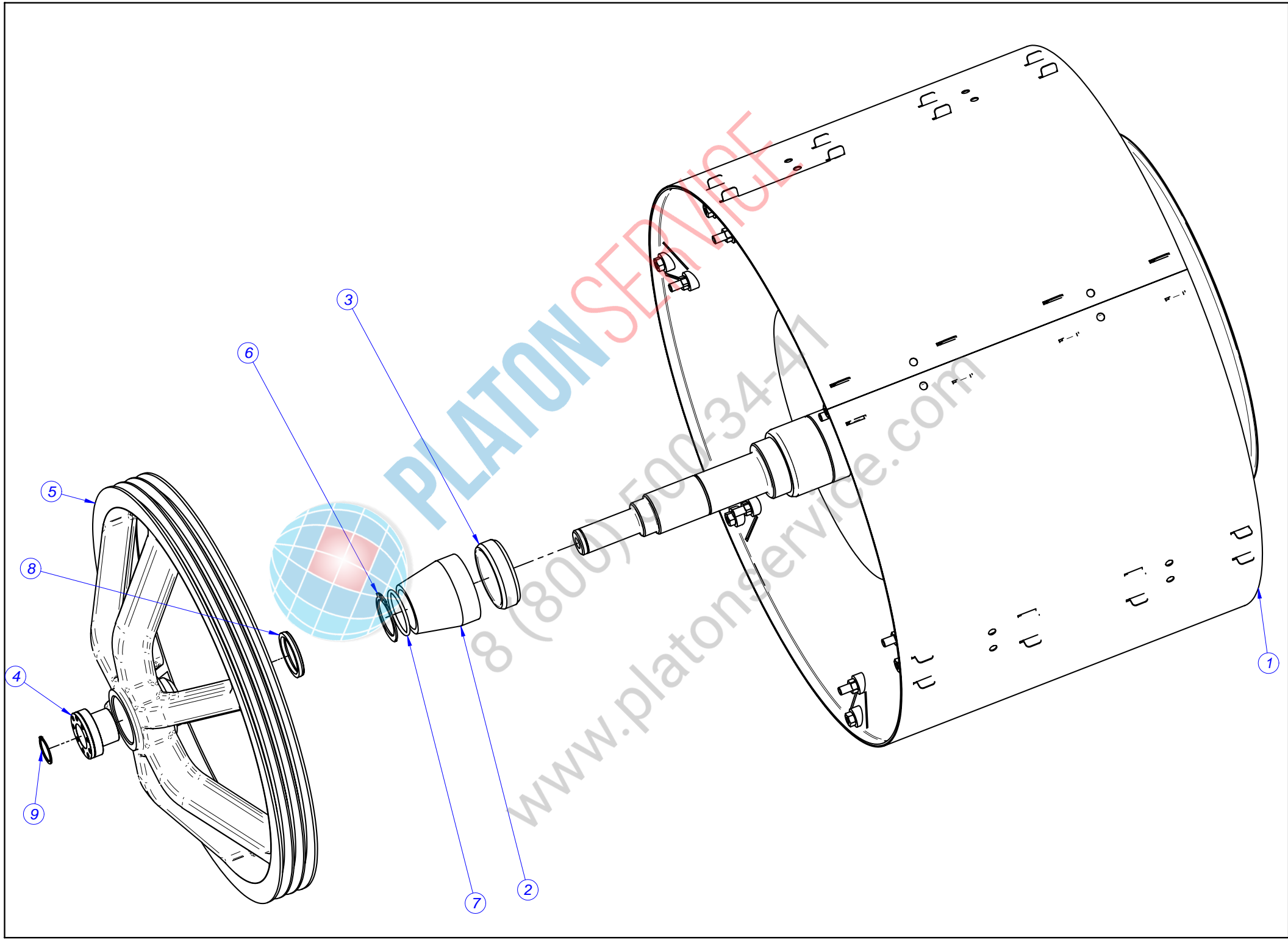

MOD.	LAVADORA 40		ZONA	TAMBOR	
Nº	CODIGO	DENOMINACION	Cant.		
1	P654905000	TAMBOR 40 COMPLETO	1		
2	P654907000	GUIA RODAMIENTO 40	1		
3	P656102000	RODAMIENTO 160/90/30	1		
4	P656024000	BUJE DE FIJACION 40	1		
5	P656015000	POLEA TAMBOR 40	1		
6	P654915000	ANILLO SEGURIDAD 65 DIN 471	1		
7	P654913000	JUNTA TORICA DIAM. INT. 65X5	1		
8	P656109000	RETEN V-RING 60	1		
9	Q301046000	ANILLO SEGURIDAD EJE 40	1		



8 (800) 500-3447

www.platonservice.com

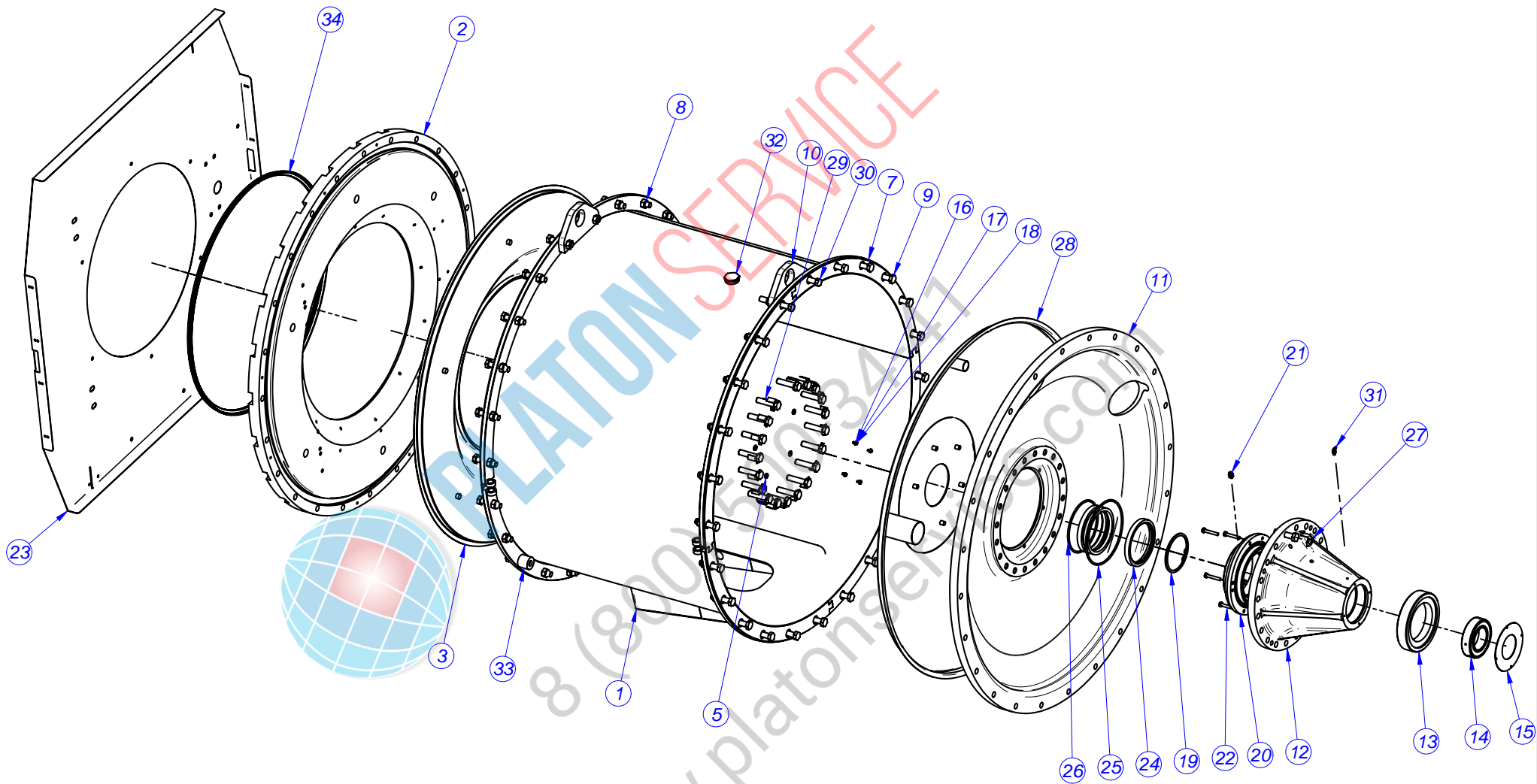

MOD.	LAVADORA 40		ZONA	CUBA	
Nº	CODIGO	DENOMINACION	Cant.		
1	P656007000	CUBA COMPL. 40	1		
2	P656003000	CONTRAPESO ANTERIOR 40	1		
3	P656008000	FRENTE CUBA 40 COMPL.	1		
4	Q232050000	ARANDELA A8	6		
5	Q242050000	ARAND.ABAN. A8 A.304	12		
6	Q012056000	TOR.EX.M8X40	6		
7	P656013000	ANILLO CUBA 40 COMPL.	4		
8	Q221347000	TUERCA EXAG.AUTOBL.M.16	50		
9	Q011399000	TORNILLO EXAG.M.16X70	67		
10	P656111000	GANCHO CUBA 40	2		
11	P656004000	SOPORTE FONDO CUBA 40	1		
12	P656009000	SOPORTE RODAMIENTOS 40	1		
13	P656103000	RODAMIENTO 100/55/25	1		
14	P656102000	RODAMIENTO 160/90/30	1		
15	P656106000	TAPA RODAMIENTOS 40	1		
16	Q232030000	ARANDELA A5	4		
17	Q242030000	ARAND.ABAN. A5 A.304	4		
18	Q012031000	TORN.EXA. M5X10 A.304	4		
19	P656016000	ANILLO SEGURIDAD 100 DIN 472	1		
20	P656005000	CASQUILLO RETENES 40	1		
21	P683017000	ENCHUFE RAP. M5- DIAM. 4	1		
22	Q012057000	TORN. EXAG. M8X50 AISI 304	5		
23	P650320000	PANEL FRONTAL 40	1		
24	P656011000	RETEN BAUMX7 110/130/12	2		
24	P656023000	RETEN BAUMX7 110/130/12 VITON	1		
25	P656107000	JUNTA TORICA DIAM. INT 170X5	1		
26	P656108000	JUNTA TORICA DIAM. INT 140X5	1		
27	P686032000	ARANDELA SEGURIDAD M16	20		
28	P656104000	FONDO CUBA 40 COMPL.	1		
29	Q012055000	TORN.EXA. M8X30 A.304	1		
30	Q151002000	TORN.EXA. M16x110 DIN 931	2		
31	P686029000	ENGRASADOR SOP. ROD.	1		
32	T305052000	TAPÓN DESAGÜE	1		
33	P666018000	CASQUILLO POSICION CUBA 60	2		
34	P636108000	JUNTA CUBA 18	1		
35	3723100000	PERFIL JUNTA CUBA 120/60/40	5		
36	P666020000	GRASA RODAMIENTOS	1		
37	3723400000	TUBO NEUM.4x2.5	1		

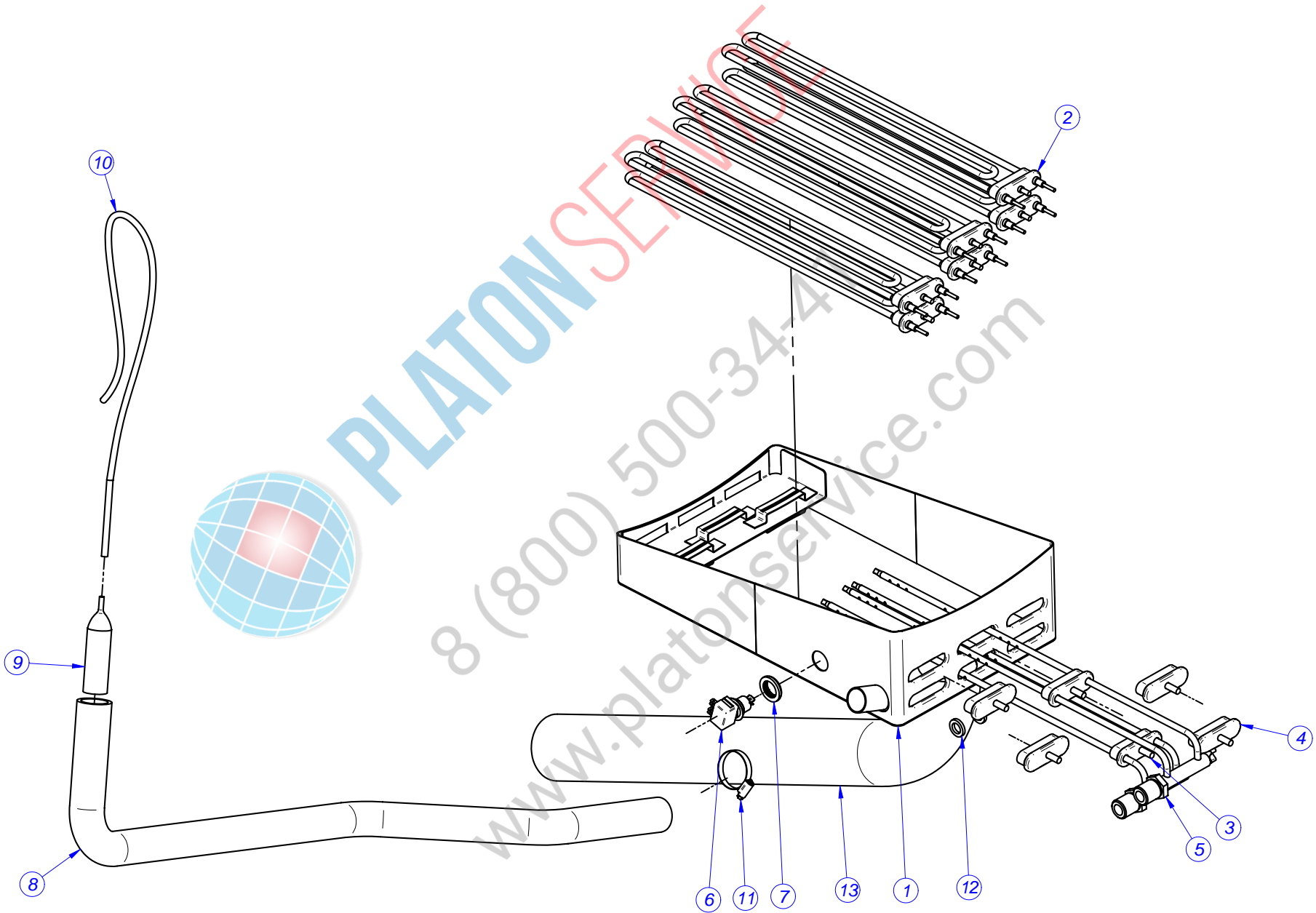



MOD.	LAVADORA 40		ZONA	CUBA	
Nº	CODIGO	DENOMINACION	Cant.		
1	P656007000	CUBA COMPL. 40	1		
2	P633002000	RESISTENCIA 4000W (VERSION ELECTRICA)	6		
2	P623005000	RESISTENCIA 3000W (VERSION AC)	3		
3	P445011000	CIERRE COMPLETO (VERSION VAPOR)	2		
4	P505008000	TAPON CIERRE COMPLETO (VERSION VAPOR)	4		
5	P655001000	INYECTOR VAPOR 40 (VERSION VAPOR)	2		
6	P503025000	SONDA	1		
7	N503017000	SOP.TERMOSTATO 1001713	1		
8	P640703000	CONDUCTO REBOSADERO 25	1		
9	P445002000	CAMARA PRESOSTATO	1		
10	3702400000	TUBO GOMA NEGRO D 8*4	1		
11	Q881306000	ABRAZADERA 32-50L	2		
12	P535024000	ARANDELA TEFLON 24X15X4	2		
13	P532120000	CONDUCTO VACIADO LC-LF 25	1		

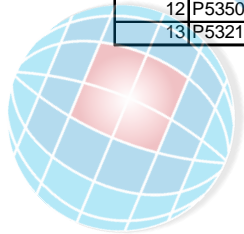

8 (800) 500-3444  
 www.platonservice.com

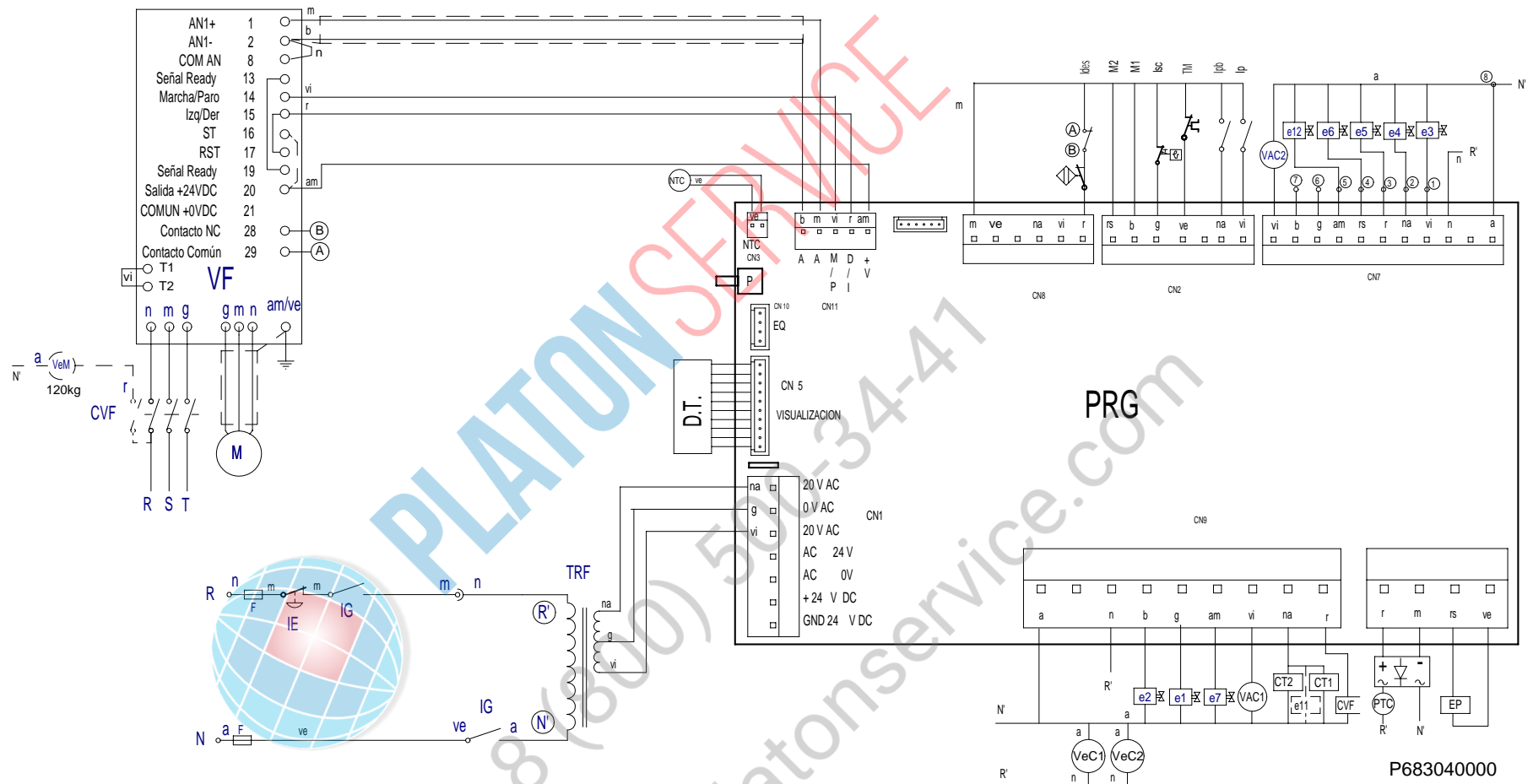

PLATON SERVICE

8 (800) 500-34-47

www.platonservice.com

Simb / LENG	ESPAÑOL	FRANÇAIS	ENGLISH	DEUTSCH	ITALIANO
CT =	Contacto Calentamiento	Contacteur Chauffe	Heating Contactor	Heizschütz	Contatore Riscaldamento
DP =	Detector posición.	Détecteur position	Position detector	Stellung Taster	Rilevatore posizione
DS1	Dosificador Neutralizante.	Doseur Neutralisant	Neutralizer feeder	Dosiervorrichtung Neutralpulmittel	Dosatore Neutralizzante
DS2	Dosificador jabon liquido.	Doseur lessive liquide	Liquid soap feeder	Dosiervorrichtung Flüssigseife	Dosatore sapone liquido
DS3	Dosificador aditivos.	Doseur additifs	Additive feeder	Dosiervorrichtung Zusatzmittel	Dosatore additivi
D.T.	Display/Teclado	Ecran/Clavier	Display/Keyboard	Display/Tastatur	Display/Tastiera
e1 =	Electro válvula agua Fria.	Électrovanne eau Froide	Cold water electrically operated valve	Elektroventil Kaltwasser	Elettrovalvola acqua Fredda
e2 =	Electro válvula agua Caliente	Électrovanne eau Chaude	Hot water electrically operated valve	Elektroventil Warmwasser	Elettrovalvola acqua Calda
e3 =	Electro válvula Prelavado.	Électrovanne Prélavage	Pre-wash electrically operated valve	Elektroventil Vorwaschen	Elettrovalvola Prilavaggio
e4 =	Electro válvula Lavado.	Électrovanne Lavage	Wash electrically operated valve	Elektroventil Hauptwaschgang	Elettrovalvola Lavaggio
e5 =	Electro válvula Lejia.	Électrovanne Eau de Javel	Bleach electrically operated valve.	Elektroventil Bleiche	Elettrovalvola Candeggina
e6 =	Electro válvula Suavizante.	Électrovanne Assouplissant	Fabric softener electrically operated valve	Elektroventil Weichspüler	Elettrovalvola Ammorbidente
e7 =	Electro válvula agua Descalcificada	Électrovanne eau Adoucie	Delimed water electrically operated valve	Elektroventil entkalktes Wasser	Elettrovalvola acqua Decalcificata
e8 ,9,10 =	Electro válvula Equilibrado	Électrovanne Équilibrage	Balancer electrically operated valve	Elektroventil Gleichgewicht	Elettrovalvola Bilanciamento
e11 =	Electro válvula Vapor.	Électrovanne Vapeur	Steam electrically operated valve	Elektroventil Dampf	Equilibrado Vapore
EP =	Electroiman de Puerta.	Électro-aimant de Porte	Door electric magnet	Elektromagnet Gerätetür	Electromagnete Porta
FI =	Filtro de Interferencias.	Filterre Anti-parasites	Interference filter	Störungsfilter	Filtro Interferenze
F =	Fusible.	Fusible	Fuse	Sicherung	Fusibile
G1,G2 =	Galga Sensor.	Jauge Capteur	Sensing gage	Meßsensor	Calibro Sensore
IE =	Pulsador Parada de emergencia.	Bouton-poussoir Arrêt d'urgence	Emergency stop push button	Not-Aus-Taster	Pulsante Arresto di emergenza
IG =	Interruptor general.	Interrupteur général	General switch	Hauptschalter	Interruttore generale
IGS =	Interruptor General de seguridad.	interrupteur Général de sécurité	General safety switch	Sicherheitshauptschalter	Interruttore Generale di sicurezza
Ides =	Intruptor de desequilibrio.	Interrupteur de balourd	Unbalance switch	Ungleichgewichtsschalter	Interruttore di squilibrio
IMo =	Interruptor Monedero.	Interrupteur Monnayeur	Coin slot switch	Münzschalter	Interruttore Portamonete
Ip =	Interruptor puerta Cerrada.	Interrupteur porte Fermée	Closed door switch	Schalter Tür geschlossen	Interruttore porta Chiusa
Ipb =	Interruptor puerta bloqueada.	Interrupteur porte verrouillée	Door lock switch	Schalter Tür verriegelt	Interruttore porta bloccata
Isc	Interruptor seguridad Temperatura	Thermostat Limiteur	Hi-limit Thermostat	Grenzthermostat	Termostato Limitatore
M =	Motor.	Moteur	Motor	Motor	Motore
Mo =	Monedero.	Monnayeur	Coin slot	Münzvorrichtung	Portamonete
NTC =	Sensor temperatura..	Capteur température	Temperature sensor	Temperatursensor	Sensore temperatura
RT =	Resistencia Calentamiento.	Résistance Chauffe	Heating Resistors	Widerstand Aufheizung	Resistenza Riscaldamento
Tm =	Térmico de Motor.	Thermique du Moteur	Motor hot-wire	Motorwärmeschalter	Termico del Motore
Tfr =	Transformador	Transformateur	Transformer	Transformator	Trasformatore
Tfr s/N =	Transformador Versión sin Neutro.	Transformateur Version sans Neutre	Transformer Version without Neutral	Transformator Modell ohne Neutralstellung	Trasformatore Versione senza Neutro
VAC =	Válvula Vaciado	Vanne Vidange	Emptying valve	Ablassventil	Valvola Scarico
Ve =	Ventilador.	Ventilateur	Fan	Ventilator	Ventola
VF =	Convertidor de Frecuencia.	Convertisseur de Fréquence	Frequency converter	Frequenzumwandler	Convertitore di Frequenza
VM =	Ventilador Motor.	Ventilateur Moteur	Fan motor	Ventilator Motor	Ventola Motore
1...8 =	Puntos conexión dosificadores.	Points raccordement doseurs	Feeder connection points	Anschlussstellen Dosiervorrichtungen	Punti connessione dosatori
<b>COLOR</b>	<b>COLORES</b>	<b>COULEURS</b>	<b>COLOUR</b>	<b>FARBEN</b>	<b>COLORE</b>
a =	Azul	Bleu	Blue	Blau	Blu
am =	Amarillo	Jaune	Yellow	Gelb	Giallo
am/ve =	Amarillo/Verde	Jaune / vert	Yellow / green	Gelb/grun	Giallo/verde
b =	Bianco	Blanc	White	Weiß	Bianco
g =	Gris	Gris	Grey	Grau	Grigio
m =	Marrón	Marron	Brown	Braun	Marrone
n =	Negro	Noir	Black	Schwarz	Nero
na =	Naranja	Orange	Orange	Orange	Arancio
r =	Rojo	Rouge	Red	Rot	Rosso
rs =	Rosa	Rose	Pink	Rosa	Roseo
ve =	Verde	Vert	Green	Grün	Verde
vi =	Violeta	Violet	Purple	Violett	Viola